



Sandia National Laboratories

30 January 2011

Pulsed Power Fusion Targets

Mark C. Herrmann, Mike Cuneo

Pulsed Power Sciences Center, Sandia National Laboratories
in collaboration with our colleagues at Sandia National Laboratories

Sandia National Laboratories is a multi-program laboratory operated by Sandia Corporation, a wholly owned subsidiary of Lockheed Martin company, for the U.S. Department of Energy's National Nuclear Security Administration under contract DE-AC04-94AL85000.

 Sandia National Laboratories



The Z pulsed power generator provides a compact MJ-class target physics platform



10,000 ft²

22 MJ stored energy
26 MA peak current
100-300 ns pulse length

Constructed in 13 Months
Cost ~ \$4/stored J

Large currents and the corresponding magnetic fields can efficiently create high energy density matter

Magnetic fields and currents can push conductors around:

$$\rho \left(\frac{\partial \mathbf{u}}{\partial t} + (\mathbf{u} \cdot \nabla) \mathbf{u} \right) = \frac{\mathbf{J} \times \mathbf{B}}{c} - \nabla P = \frac{1}{4\pi} \mathbf{B} \cdot \nabla \mathbf{B} - \nabla \left(P + \frac{B^2}{8\pi} \right)$$

Magnetically-Driven Implosion

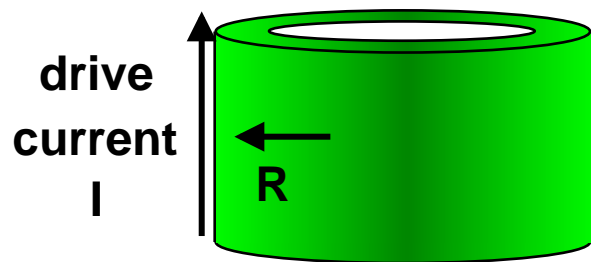

$$B \sim \frac{I}{R} \quad P \sim B^2 \sim \left(\frac{I}{R} \right)^2$$

100 MBar at 26 MA and 1 mm

- Magnetic drive can reach very high drive pressures if current reaches small radius
- Magnetic drive is very efficient at coupling energy (no energy wasted on ablation)

Wire array Z-pinches efficiently radiate soft x-rays

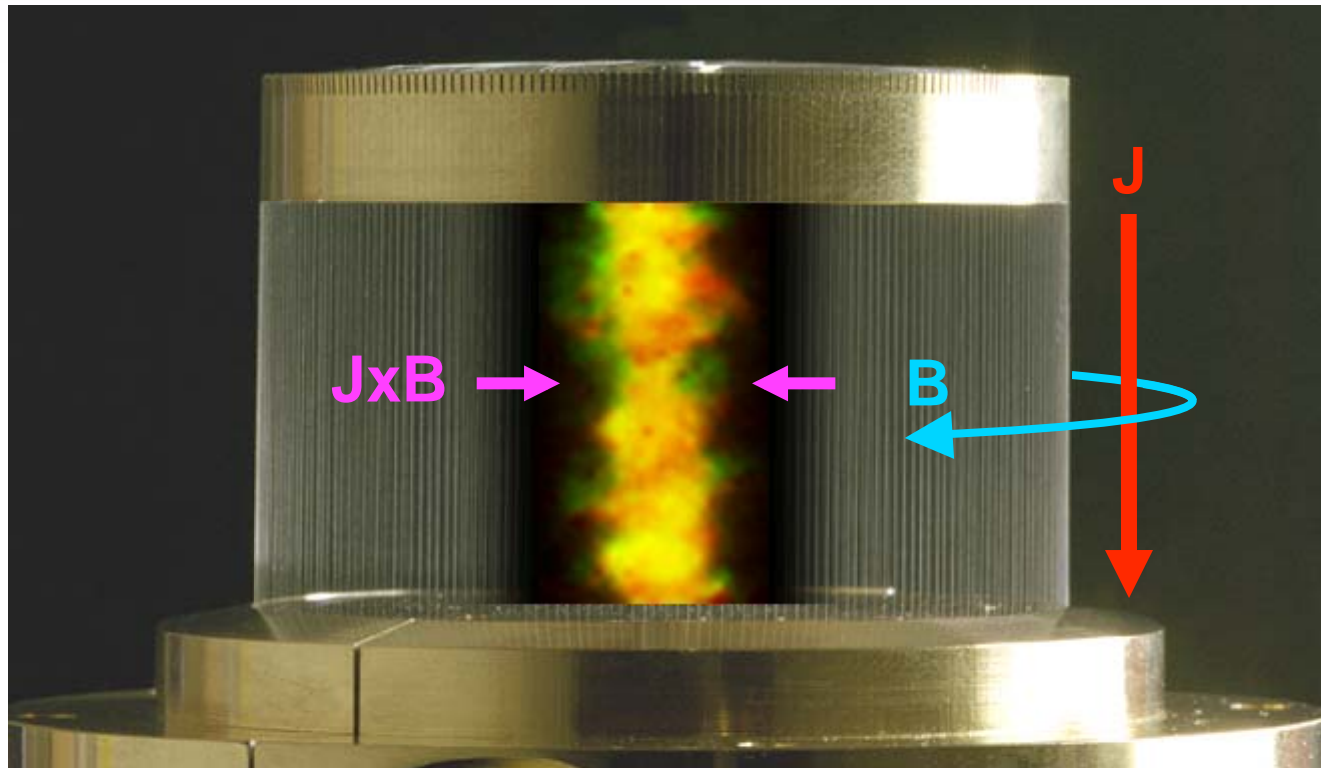

$P_{\text{rad}} \sim 330 \text{ TW}$, $Y_{\text{rad}} \sim 2 \text{ MJ}$
 $> 10\%$ wall plug efficiency

Integrated LASNEX simulations demonstrate 400+ MJ fusion yield in a pulsed-power z-pinch driven hohlraum

Double z-pinch hohlraum fusion concept

R. A. Vesey, M. C. Herrmann, R. W. Lemke *et al.*,
Phys. Plasmas (2007)

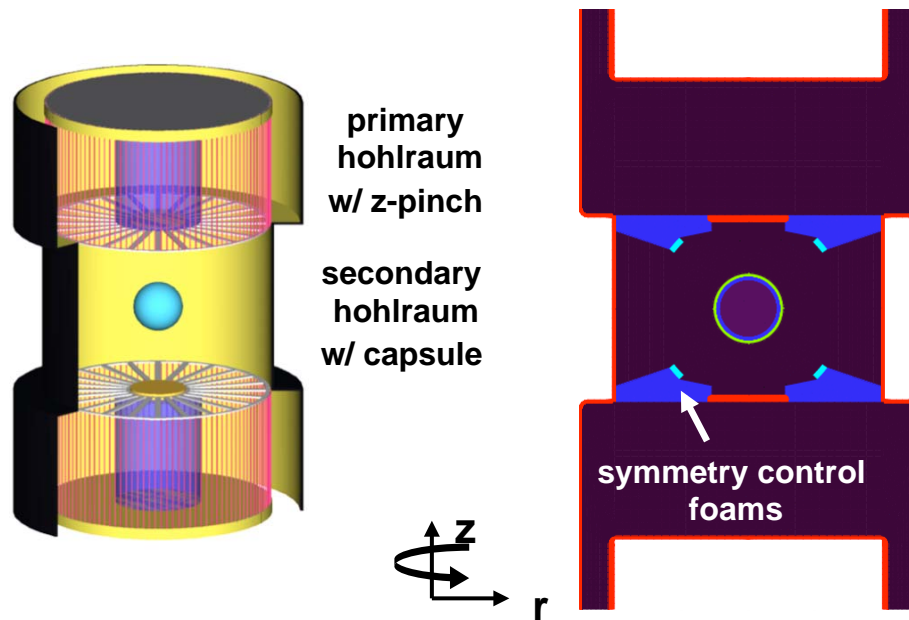

Inefficiencies lead to only 0.04% of the driver wall plug energy in the fusion fuel

High yield capsule design

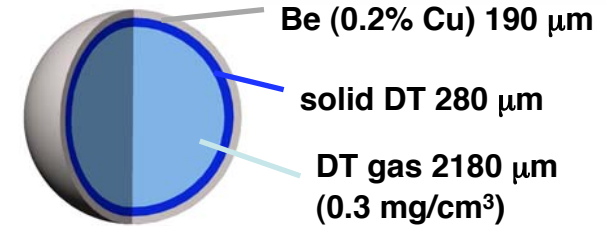

Fuel density at ignition

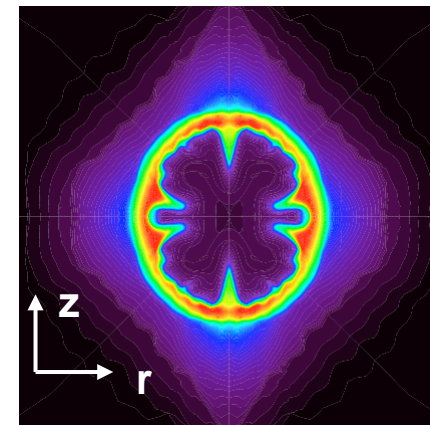

1D capsule yield 520 MJ
2D integrated yield 470 MJ

Direct fuel compression and heating with the magnetic field could be 25X more efficient than indirect-drive

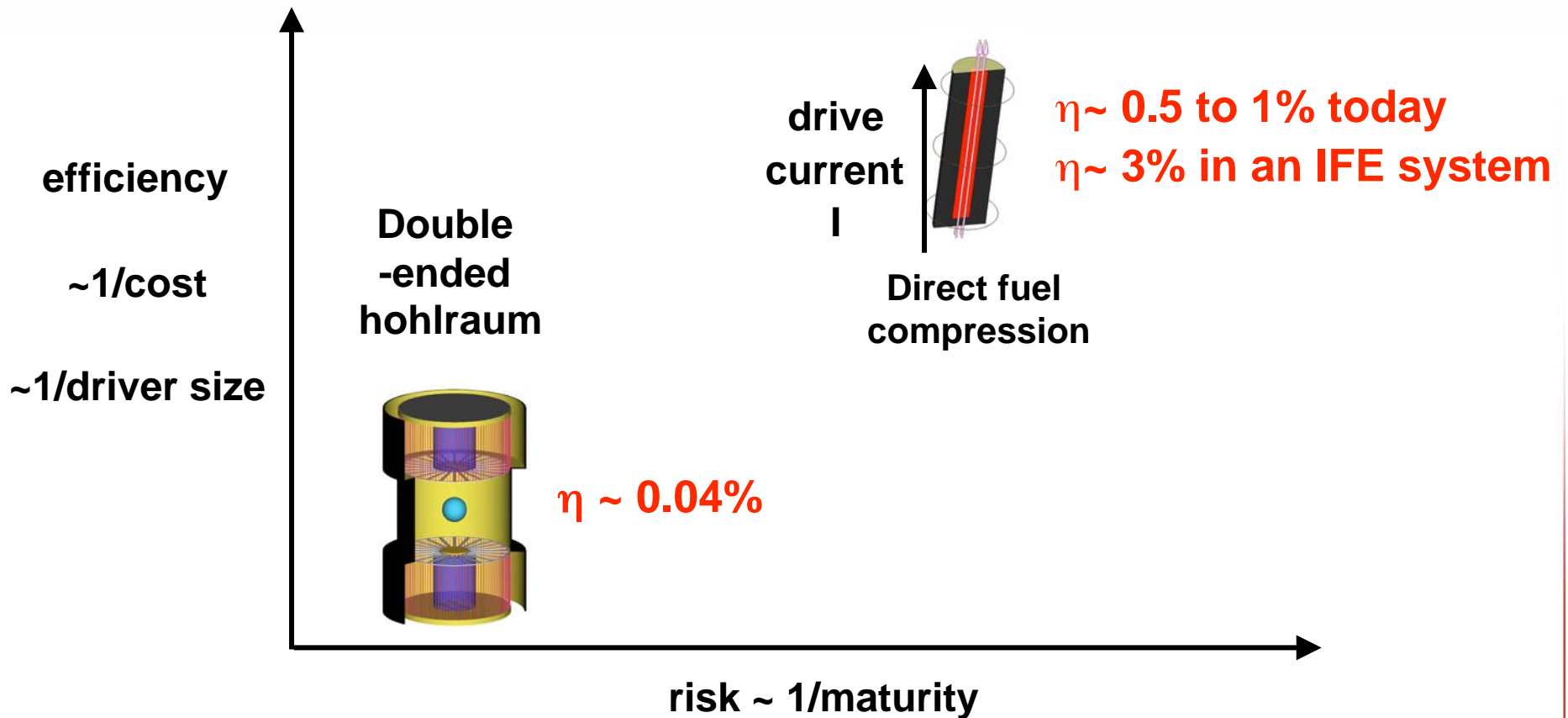

- A near term directly driven concept we can test is Magnetized Liner Inertial Fusion
- Other High Yield/ High Gain concepts are also being explored

The Z facility provides a unique opportunity to test the Magnetized Liner Inertial Fusion (MagLIF) concept

1. A 10-30T axial magnetic field is applied to inhibit thermal conduction and enhance alpha particle deposition before the implosion begins

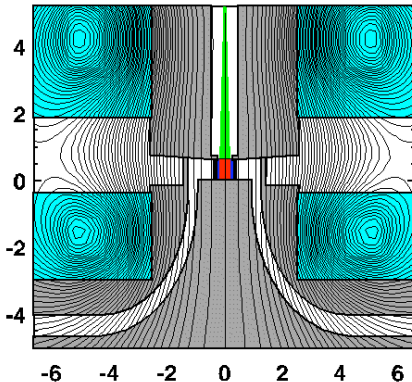
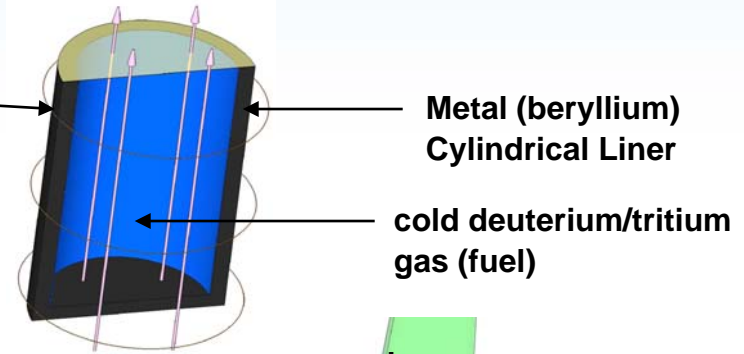

2. Z Beamlet can preheat the fuel to ~100 - 1000 eV to reduce the require compression needed

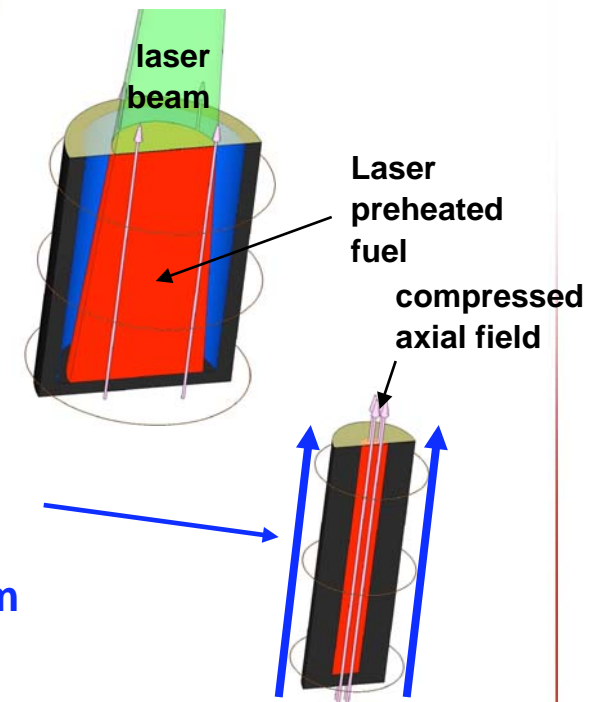

3. The Z accelerator can provide the drive current which generates an azimuthal drive field (pressure) to efficiently implode the liner (Z pinch) at 50-100 km/sec and compress the axial field by factors of 1000

* S. A. Slutz *et al.*, Physics of Plasmas 17, 056303 (2010).

**Simulations indicate scientific breakeven
(fusion energy out = energy deposited in fusion fuel)
may be possible on Z**

INITIAL CONDITIONS

| | |
|--------------------------------|---------|
| Peak Current: | 27 MA |
| Be Liner R0: | 2.7 mm |
| Liner height: | 5 mm |
| Aspect ratio (R0/ Δ R): | 6 |
| Initial gas fuel density: | 3 mg/cc |
| Initial B-field: | 30 T |

FINAL CONDITIONS

| | |
|-----------------------------|----------|
| Energy in Fusion Fuel | ~200 kJ |
| Target Yield: | 500 kJ |
| Convergence ratio (R0/Rf): | 23 |
| Final on-axis fuel density: | 0.5 g/cc |
| Peak avg. ion temperature: | 8 keV |
| Final peak B-field: | 13500 T |
| Peak pressure: | 3 Gbar |

**60 nm surface roughness,
80 (μ m) waves are resolved**

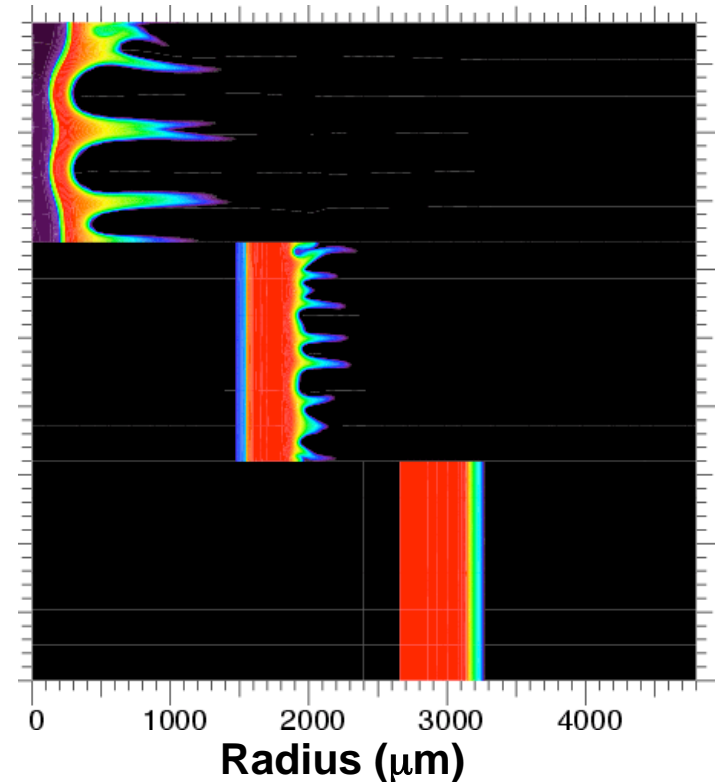

2D yield for a DT target ~ 350 kJ (70% of 1D)

**The magneto-Rayleigh Taylor instability is the
biggest concern for this concept**

The physics issues for direct magnetic-drive targets are similar to those for other inertial fusion concepts

Stabilization techniques

Instability growth

Fuel Preheat

Convergence ratio

Fuel Premagnetization

Implosion time and velocity

drive
current
 I

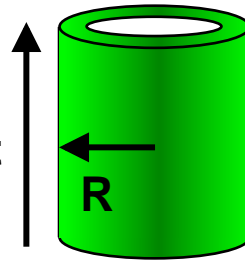

Driver coupling

Pusher-fuel mix

Pusher adiabat

r - θ symmetry

- We are conducting a vigorous research program to validate the general class of magnetically-driven targets on the Z facility at the MJ target scale

We have already developed most of the capabilities required to test MagLIF on the Z facility, rest are imminent

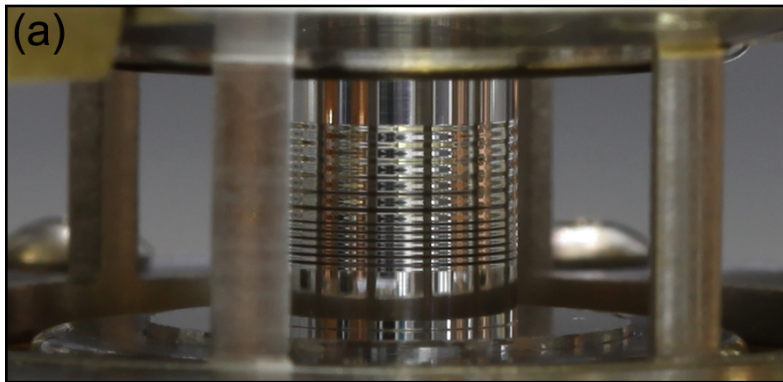

(a) High-quality target fabrication on site



Cryogenic cooling of liner targets has been demonstrated (liquid D2)

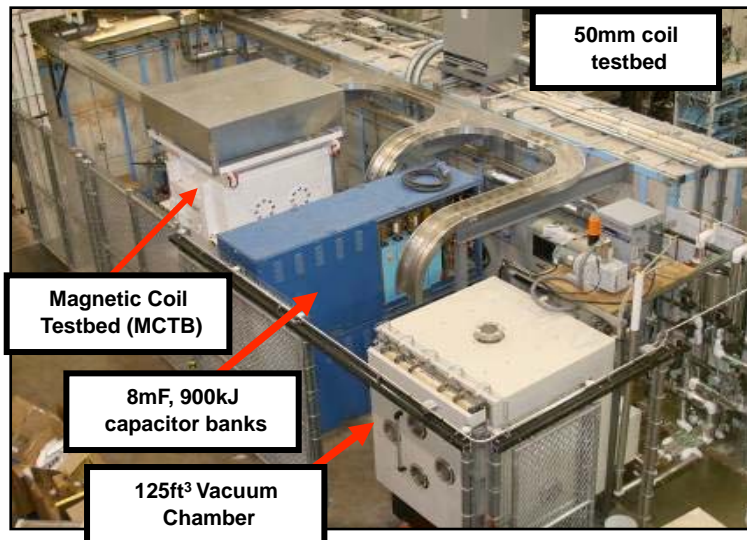

Test facility for coil development on site

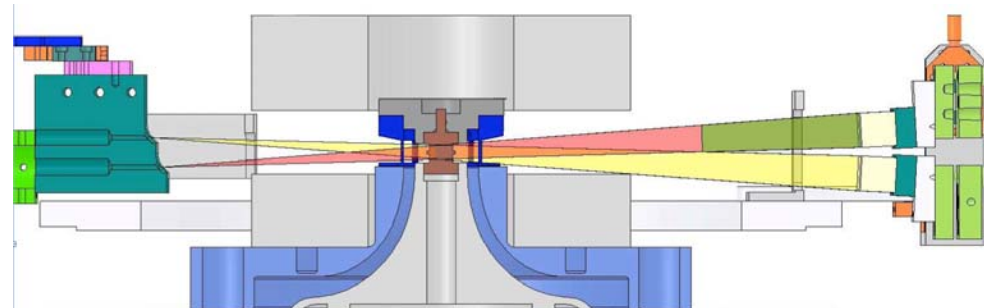

10 T coil designs allowing diagnostic access on Z will be tested

We observe excellent agreement between theory and experiment for single-mode MRT growth experiments

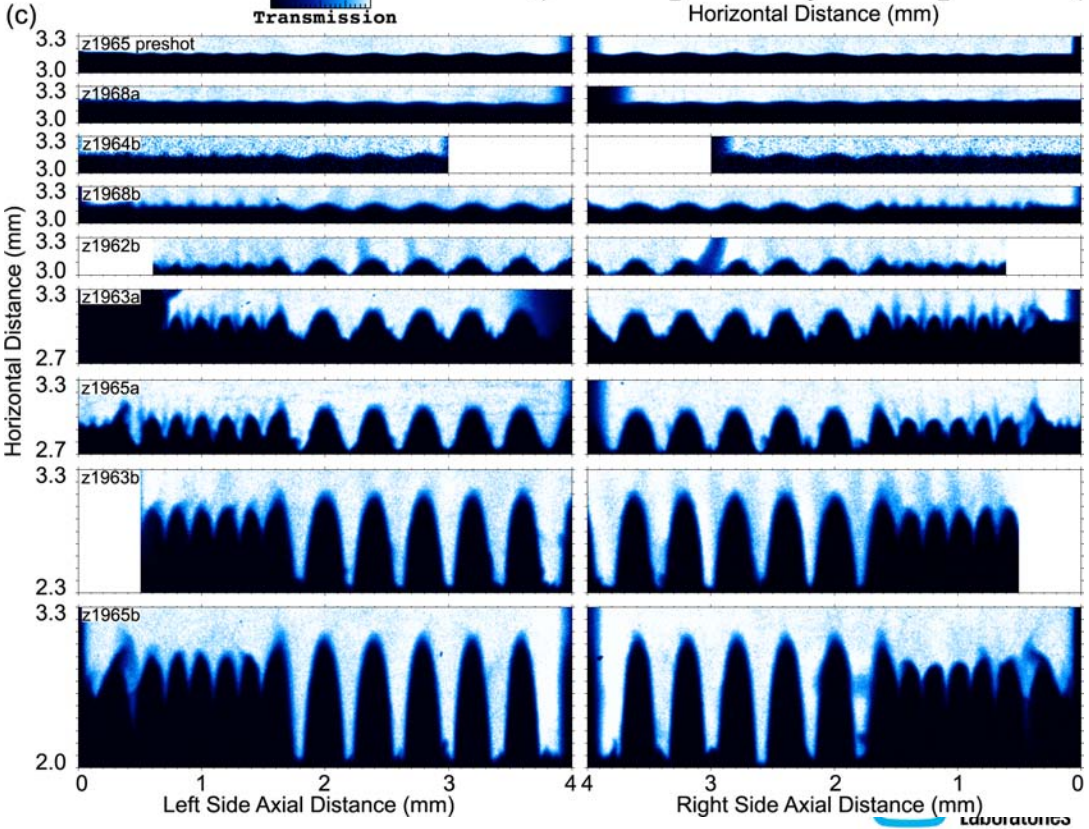
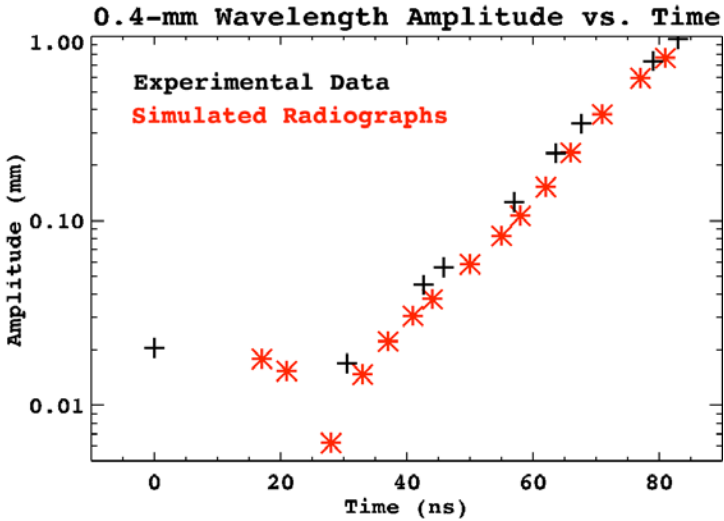
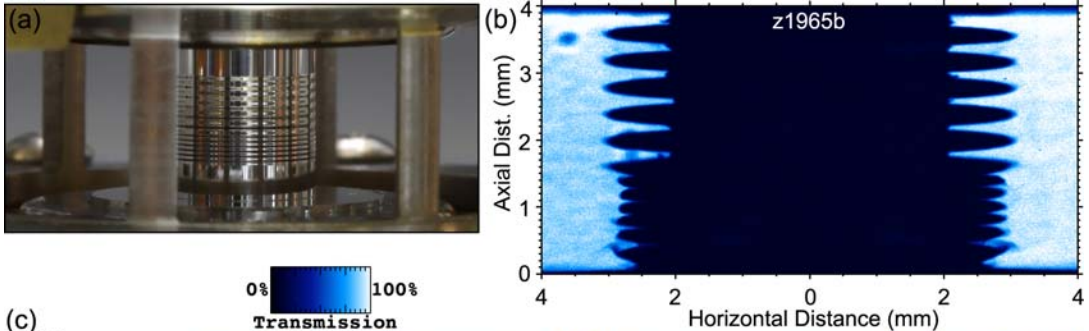
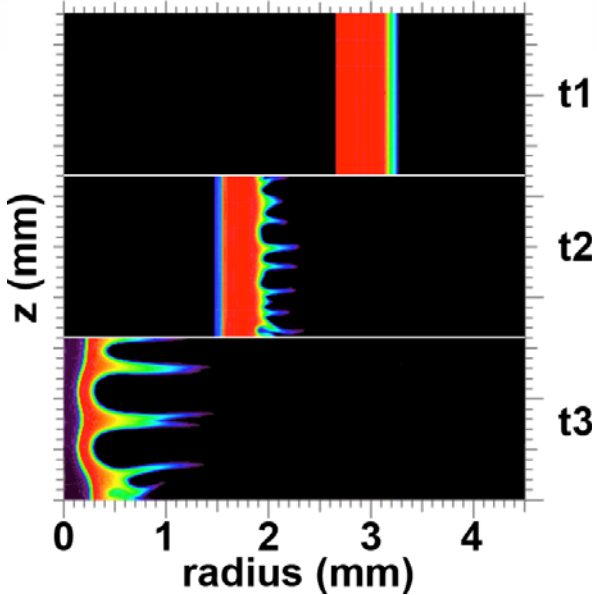

A levitated shell version of MagLIF could give high yield and high gain on a larger facility

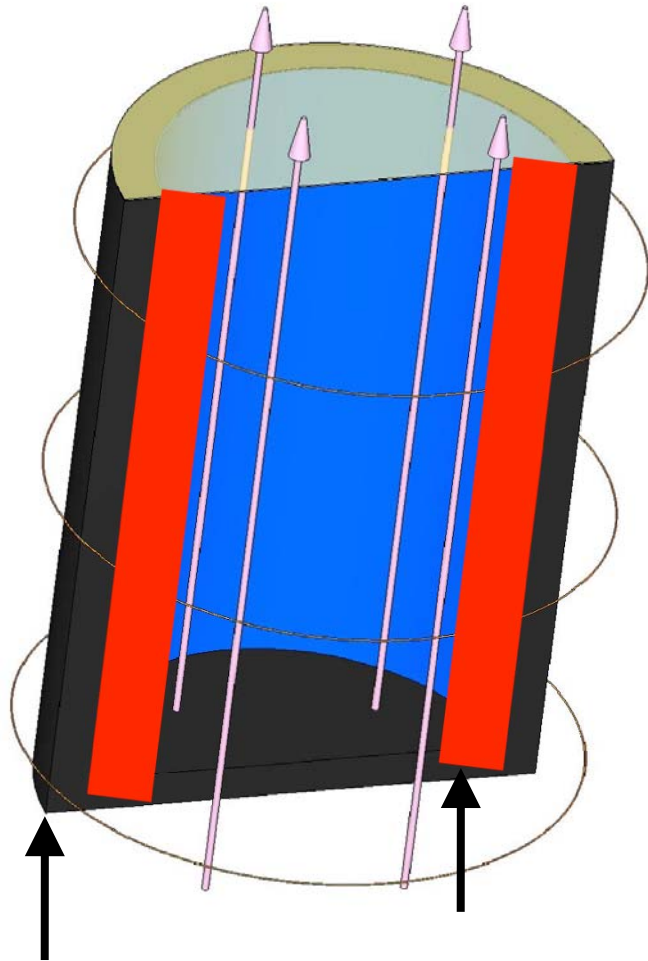

Aluminum Liner

DT shell

INITIAL CONDITIONS

| | |
|---------------------------------|----------|
| Peak Current: | 61 MA |
| Al Liner R0: | 4.4 mm |
| Liner height: | 10 mm |
| Aspect ratio ($R0/\Delta R$): | 6 |
| Initial gas fuel density: | 10 mg/cc |
| Initial B-field: | 10 T |

FINAL CONDITIONS

| | |
|--------------------------------|----------|
| Target Yield: | 4.8 GJ |
| Target Gain: | 700 |
| Convergence ratio ($R0/Rf$): | 22 |
| Final on-axis fuel density: | 9.3 g/cc |
| Final peak B-field: | 12500 T |



Summary

Pulsed power is an efficient, inexpensive way to create matter at high energy densities

Magnetically driven implosions offer a path to coupling much higher fractions of the driver stored energy to fusion fuel

Magnetized Liner Inertial Fusion (MagLIF) offers a near term chance for testing our understanding of magnetically driven implosions. If successful, would lead to breakeven with DT.

Experimental data on the Magneto-Rayleigh Taylor instability is promising, we hope to do an integrated MagLIF test in 2012.

A high-yield (GJs), high-gain (>500) MagLIF design is under development. Much of the relevant physics can be tested on Z.



Backup

A large, embedded magnetic field significantly expands the space for fusion self heating

*Basko et al. *Nuc. Fusion* **40**, 59 (2000)

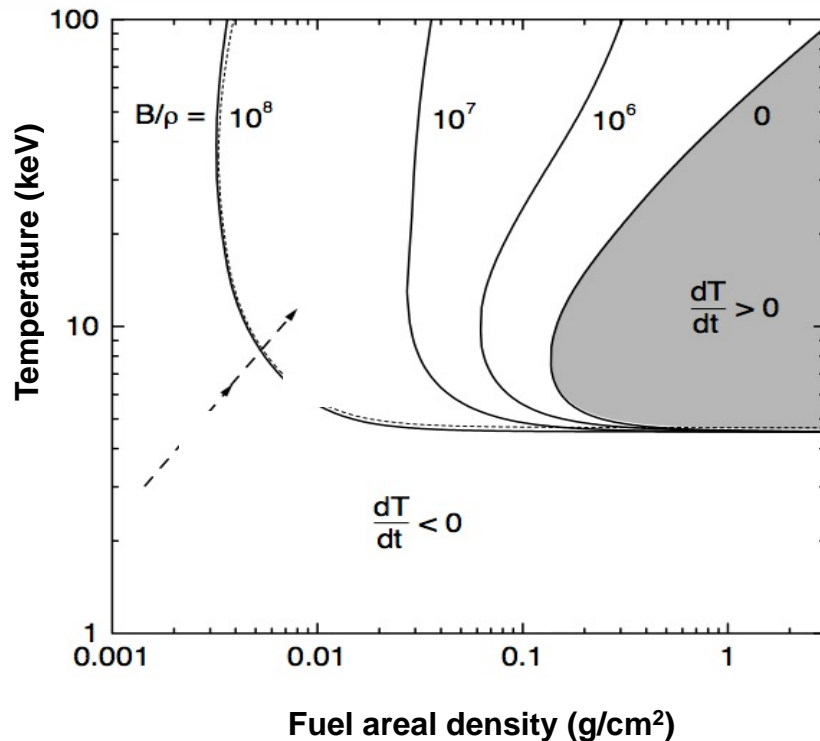

The ρr needed for ignition can be significantly reduced by the presence of a strong magnetic field

- inhibits electron conduction
- enhances confinement of alpha particles

Lower ρr means low densities are needed (~ 1 g/cc \ll 100g/cc)

Pressure required for ignition can be significantly reduced to ~ 5 Gbar (\ll 500 Gbar for hotspot ignition)

Large values of B/ρ are needed and therefore large values of B are needed.

$B \sim 50$ - 150 Megagauss $\gg B_0$ -> flux compression is needed